

# SinBaD Moisture Shield Instructions, 826-1752

Included in Kit 826-1752		
Part Number	Quantity	Description
819-5868	1	Instructions
826-1752	1	Shield

Follow these steps to install the shield in pre-7/99 SinBaD II french fry dispensers. The shield protects the unit's motor driver board from moisture, often introduced during cleaning.

- Remove power from unit.
- Remove two screws holding the back cover in place and set back aside.
- Inspect component board holding the driver board, transformer, etc. See Fig 2. The component boards in units built before 7/99 extend only an inch or more above the driver board.
- Remove the two screws holding the component board to the cabinet. They will be used to hold the shield in place.
- Sit shield in place. Ensure its leading edge slips over the top of the component board and no wires are pinched by the edges of the shield. Most wires should emerge from the bottom left side of the shield.
- Secure in place with screws previously removed.
- Reinstall back and return unit to service.

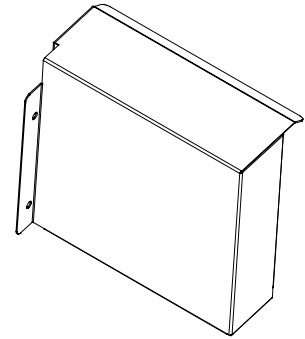

Figure 1: The shield protects the motor driver board in the SinBaD II from moisture.

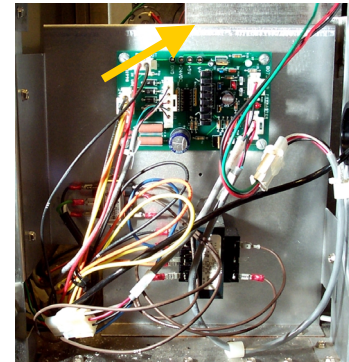

Figure 2: The component board on pre 7-99 SinBaD II units extends only an inch or more above the driver board. These units should have the shield installed.



Figure 3: The shield is installed using the two screws in the cabinet wall. Ensure the leading edge of the shield slips over the top of the component board and no wires are pinched by the edges of the box. Most wires should emerge from the bottom of the shield